

System with $< 6'-6\frac{3}{4}"$; Auxiliary rails width: $2\frac{3}{8}"$
 System with $> 6'-6\frac{3}{4}"$; Auxiliary rails width: $4\frac{3}{4}"$
 * $3\frac{3}{8}"$ Auxiliary rails upon request

1. SINGLE-NORMAL SIZE HEADBOX	7.
2. MOTOR 120VAC /60HZ TO 24VDC	SHOP FINISH:
3. SMOKE SEALED CURTAIN UL1784	COMPLETE HEADBOX POWDER COATING
4. EGRESS SWITCH FOR RE-OPENING	RAL9010 - PURE WHITE
5. OPTIONAL FULL OR STUB RAILS (IN FRONT OF THE WALL)	
6. WALL MOUNTING BRACKET	

RevNo	Revision note	Date	Signature	Checked

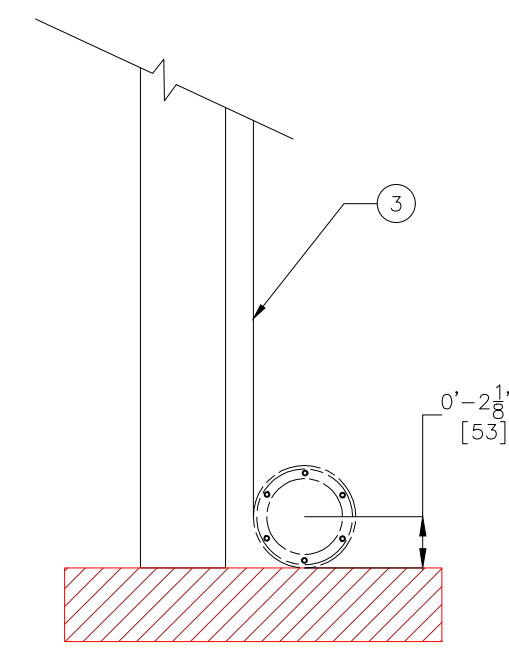
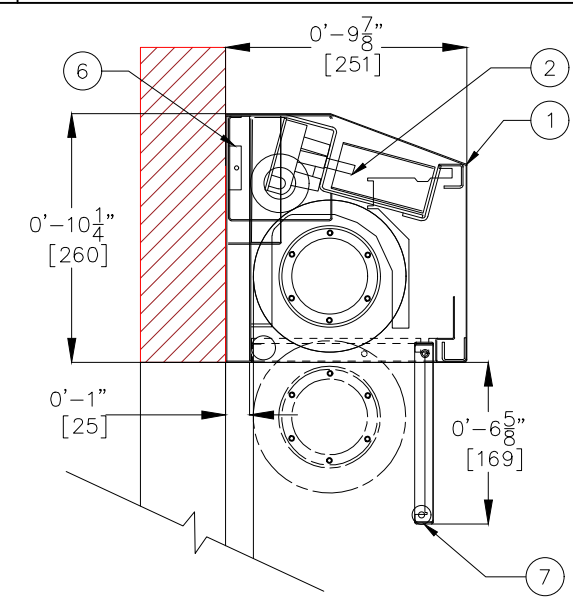

CROSS SECTION VIEW

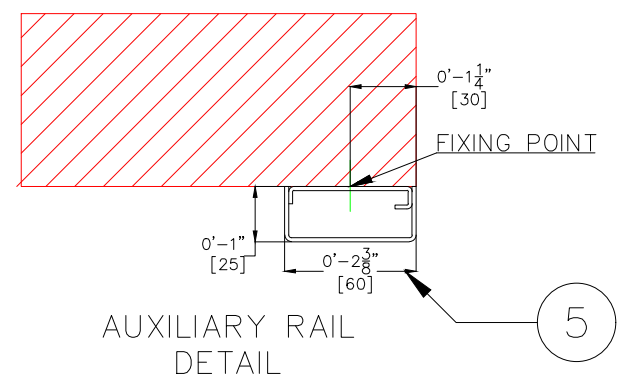
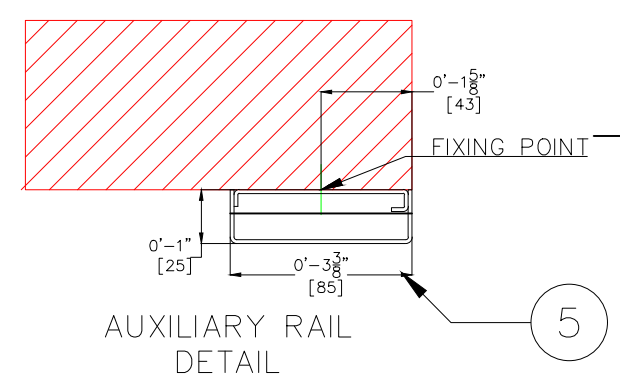
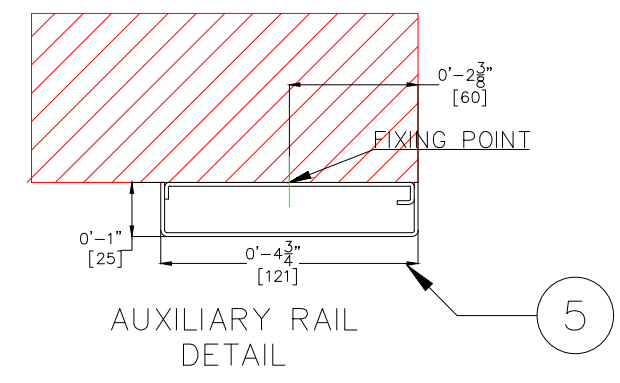

NOMENCLATURE GX/2/WIDTH/HEIGHT/X/864/PS9010		QTY: XXXX UNIT	QUOTE NUMBER: M-XXX	SCALE DO NOT SCALE
JOB:		 5711 THOMAS ROAD CANANDAIGUA, NY 14424 (585) 412-2179 www.firecurtaintechnologies.com		
CUSTOMER:				
SIZE:	WIDTH x HEIGHT [WIDTHmm x HEIGHTmm]	WEIGHT:	SMOKE CURTAIN GX2	
DATE:	2021-11-12	TBD	DRAWING NO. 1/1	
DRAWN BY: DAVID GUEVARA				