



**FIRE CURTAIN
TECHNOLOGIES**

Smoke and Fire Curtains

FIRE RATED CURTAIN AUTOMATIC FIRE CURTAIN FM 1

Automatic Fire Curtains FM-1 are used where, if there is a fire, it is necessary to create a temporary barrier within an opening which seals off the area on fire. The curtain descends automatically and prevents fire and smoke from spreading from one area to another. It also allows people access to protected escape routes without any loss of fire resistance.

APPLICATIONS:

Fire Rated Curtain FM-1 can be installed in nearly every kind of building, from residential to retail to industrial.

Fire resistance



60 minutes



120 minutes

PRODUCT DATA SHEET | AUTOMATIC FIRE CURTAIN FM 1

KEY FEATURES

Fire resistance test according to **EN 1634-1**.

Continuous performance test (10,000 cycles) in accordance with:

DIN 4102-18

Classified to **EN 13501-2**.

Fire resistance + integrity: **E60-C, E120-C, E180-C**

Limitation of heat radiation: **EW30-C**

Self-closing feature: **C2**

Fire rating:

1 hour - 1700°F

Glass fabric

3 hour - 1920°F

Glass fabric with coating and stainless-steel inlay

Materials class: **A2-s1, d0**

Manufactured in accordance with ISO 9001:2008

PRODUCT DESCRIPTION

FM-1 fire curtains are lightweight and compact, which enables them to be installed easily in a place with space constraints such as a false ceiling. They have been tested as fire barriers in accordance with EN 1634-1, providing protection for a defined period and at a defined maximum temperature.

A FM-1 Fire Curtain comprises a flexible fire-resistant fabric which is wound around a circular tube. Upon receiving a signal from the fire alarm system or on loss of power, the curtain automatically unwinds to its operational position.

Applications for fire curtains

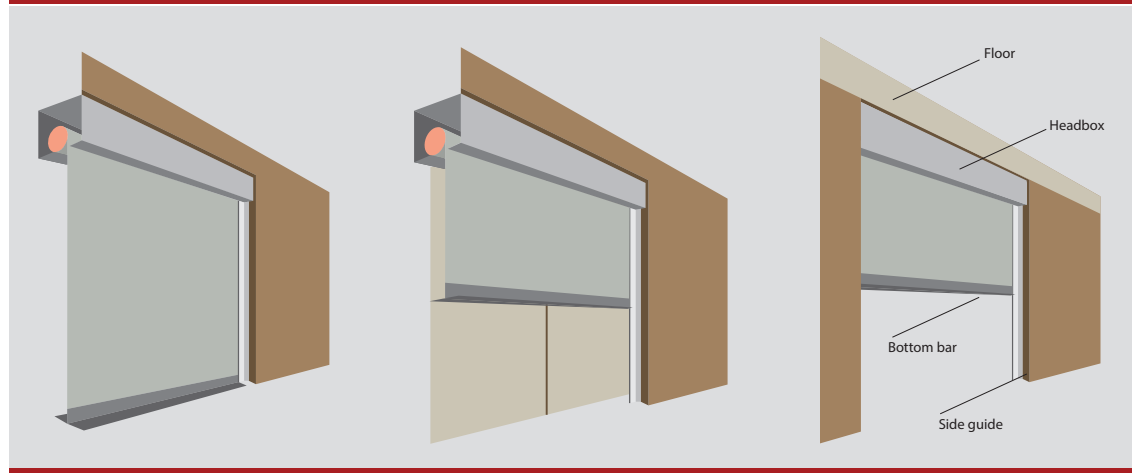

- (1) The obvious application for a FM fire curtain is as a direct **replacement for a fire door or a fire shutter**. It doesn't mean to say that the curtain will be used as a door in everyday use, but it would normally be intended to keep it open most of the time and just to close it in emergency or under test conditions.
- (2) FM Fire curtains are also often used **to protect lift doors**. There is an application where the lift doors themselves are not fire rated but a fire rating is needed at that location, then simply dropping in a fire curtain in front of the lift doors is a common way of providing this.
- (3) Where there is a relatively large void being used as a smoke shaft, then that void can be closed off using a FM fire curtain. In normal circumstances such a shaft would be closed off using a damper or ventilator of some type, if the opening is too big for a ventilator or damper, a fire curtain could be employed **to close off the shaft on the levels where there is no fire**.

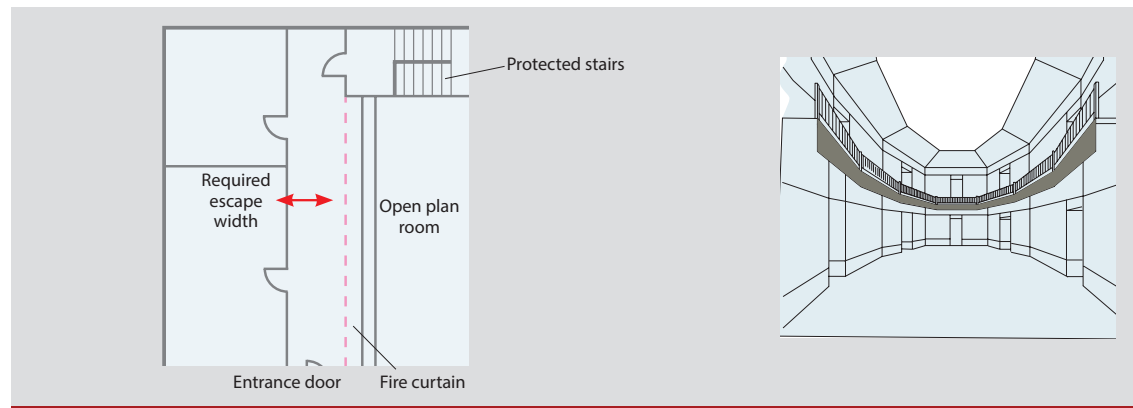

- (4) Another common application is in an open plan dwelling. If in the case of a fire people are trying to escape from the upper floors, then they might well have to pass by the fire to get to an exit. In such circumstances it is quite common to have fire curtains which will drop in case of fire to **provide a protected route from the upper floors to the final exit**. Another common use is just as small curtains, basically replacing fire shutters across counters, serveries, service shafts and so on. The main reason that people would use a fire curtain rather than a fire shutter is simply that it tends to be smaller and neater and less expensive.
- (5) If there is a **narrow atrium balcony** then it is quite common to be required to use a fire curtain rather than a smoke curtain for that particular application.

PRODUCT DATA SHEET | AUTOMATIC FIRE CURTAIN FM 1

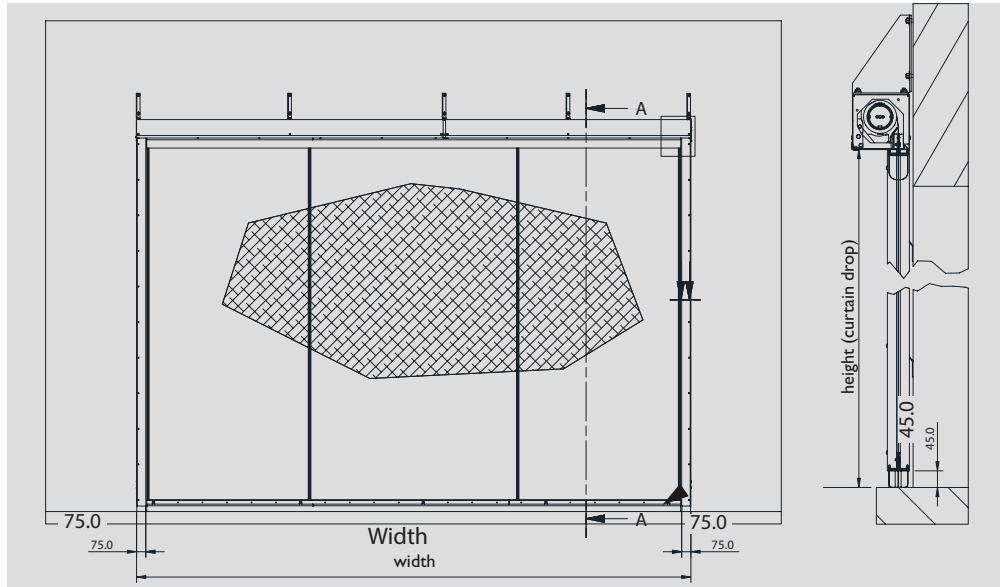

Design

- Stable headbox
- Invisible once installed
- Variable headbox sizes and versions
- Alternative roller and rod guide systems
- Side guide roller system ensures that the curtain will close under air pressures

Controls

- Easy to use controls
- 48 V DC gravity fall motor
- Intelligent electronics
- Speed of descent limited to 0.15 m/s
- Option of an emergency opening button for personnel leaving an area
- Option of a fireman's override button
- Option of a safety bottom bar to retract curtain if there is an obstruction
- Option for intermediate stop
- Option for multi-tone siren and strobe light



Features and benefits

High and certified performance

The Automatic Fire Curtain FM1 have been tested as fire barriers for either 60, 120 or 180 minutes resistance, in accordance with EN 1634-1. It has a E60-C, E120-C and E180-C rating in accordance with EN 13501-2, thereby achieving an integrity rating for either 60, 120 or 180 minutes.

The **E 60**, **E 120** and **E 180** fabrics achieve the building class A2 S1 d0 to EN 13501-1.

The **E120-C** and **E180-C** versions also have class EW 30 in accordance with EN 13501-2, which demonstrates that the fabric re-radiates only a limited amount of heat.

The Fire Rated Curtain FM-1 has achieved a successful a continuous life cycle test (10,000 cycles) in accordance with DIN 4102-18.

No power needed to operate it

The Fire Curtain FM-1 unwinds to its operational position under the influence of gravity in a "gravity fail-safe" manner even if power is lost.

Can accommodate thermal movement

All major components are fitted with expansion joints, which results in a high temperature resistance of the product.

A wide range of options

The Automatic Fire Curtain FM-1 can easily be adapted to the physical constraints of the building. All system components – headboxes, fabric, bottom bars, drive systems – can be customised to your needs.

Easy to install and maintain

The FM-1 Fire Curtain is delivered in modular form and as such is easy to install. The bottom of the headbox is closed off with a panel which also allows the entire length of the system to be accessed for servicing.

Virtually invisible when rolled up

There are no visible fixings either on the underside of the headbox or on the bottom bars. The headbox, the bottom bar and the side guides can be powder-coated to a RAL color to blend in with the building.

Compact and low in weight

A FM-1 fire curtain is lightweight and compact, which enables it to be installed easily in a place with space constraints such as a false ceiling. Such a roller fire curtain is much less obtrusive than a roller shutter with a comparable performance.

Maximum Curtain Drop (ft)

Housing type	Classification	Roller length (W)	Drop (H)
SI Standard Single Unit N	60 minutes	14'-9 1/8"	12'-3 5/8"
	E180, E120, E 30	14'-9 1/8"	9'-0 1/4"
SI Standard Single Unit L	60 minutes	13'-1 1/2"	19'-8 1/4"
	E180, E120, E 30	13'-1 1/2"	18'-0 1/2"
DH-DV Double Unit N	180 minutes	∞	9'-0 1/4"
DH-DV Double Unit L	180 minutes	∞	18'-0 1/2"

PRODUCT DATA SHEET | AUTOMATIC FIRE CURTAIN FM 1

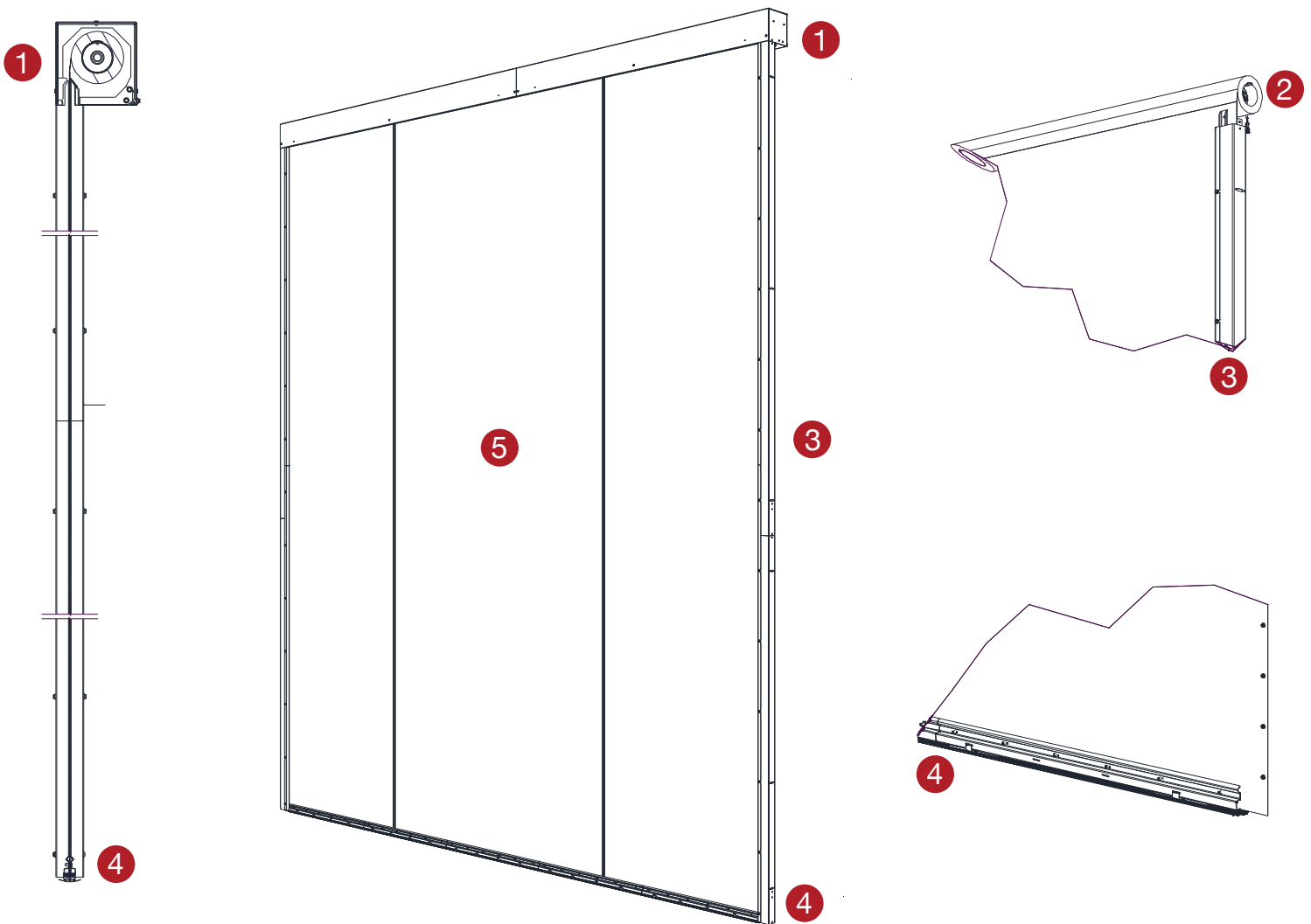

There are four main components:

- 1 Head box
- 2 Roller
- 3 Side guides
- 4 Bottom bar with seal
5. Curtain fabric